



**VERTICAL DOORS, INC.**™  
*VerticalDoors.com*

**SIMPLY UPLIFTING**™

542 3rd St. Lake Elsinore, CA 92530

Tel: 951.273.8669: Fax: 951.245.5481



**CORVETTE "C5" 1997-2004**

U.S. PATENTS

#6,808,223; #6,845,547; #7,140,075; #7,059,655

PATENTS AGGRESSIVELY ENFORCED!

**PLEASE CAREFULLY READ ALL INSTRUCTIONS BEFORE  
ATTEMPTING TO INSTALL THIS PRODUCT.**

**FOR QUESTIONS PLEASE  
CONTACT US AT (951) 245.8669**

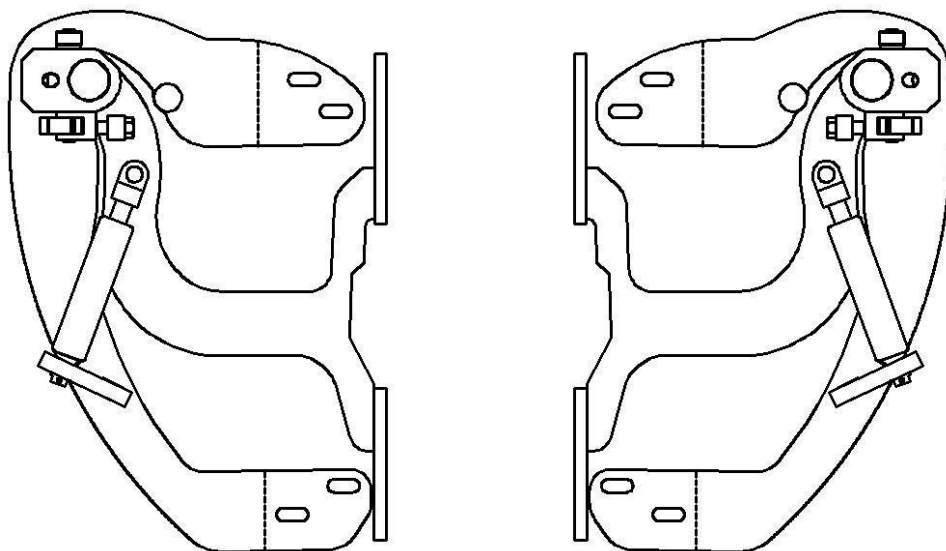

**THIS KIT INCLUDES:**

- 8 M8-1.25X40MM BOLTS WITH WASHERS
- 8 M8-1.25X30MM BOLTS WITH WASHERS
- RIGHT AND LEFT HINGE ASSEMBLY
- WIRE LOOM
- 2 SHOCKS 565 PSI
- 2 SHOULDER BOLTS WITH WASHERS
- 2 PINS

**TOOLS REQUIRED FOR INSTALLATION:**

	<ul style="list-style-type: none"> <li>➤ AIR RACHET, GRINDER AND CUTTER.</li> </ul>
	<ul style="list-style-type: none"> <li>➤ 7MM, 8MM, 10MM, 11MM, 13MM, SOCKETS AND EXTENSION.</li> </ul>
	<ul style="list-style-type: none"> <li>➤ FORK AND PHILLIP'S SCREW DRIVERS</li> </ul>
	<ul style="list-style-type: none"> <li>➤ SPACERS FOR THE DOOR GAP.</li> </ul>
	<ul style="list-style-type: none"> <li>➤ 3/16 ALLEN WRENCH</li> </ul>
	<ul style="list-style-type: none"> <li>➤ 1/4 &amp; T15 TORX BIT</li> </ul>
	<ul style="list-style-type: none"> <li>➤ 9/16 WRENCH</li> </ul>
	<ul style="list-style-type: none"> <li>➤ LOCKTITE RED</li> </ul>

**OTHER TOOLS MAY BE NEEDED DEPENDING ON YOUR VEHICLE.**



**(Note: The pictures on the manual are for reference only they may not match your vehicle.)**

**1) Disconnect the battery.**

**2) Remove the headlight covers:**

Open the hood and remove the (2) T-15 Torx (PIC. 1).

Remove (3) Phillip's screws to remove the headlight cover (PIC.2)

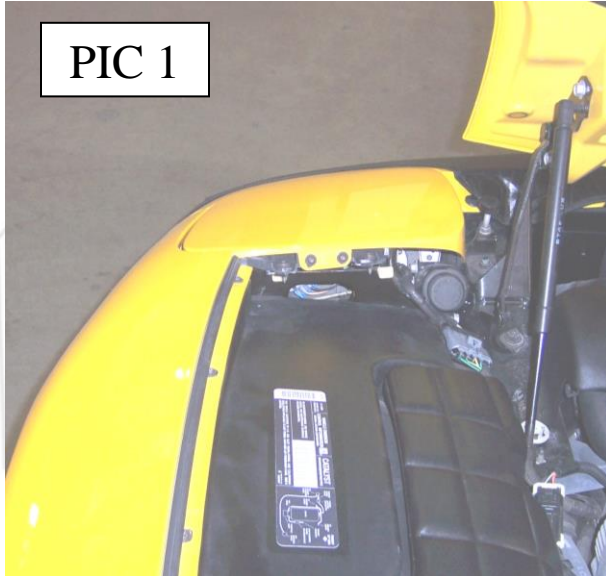

Remove (4) T-15 Torx screw this will release fiberglass headlight cover (PIC 3.)

Now you will be able to remove the head light cover.

Remove (4) T15 Torx screws this will release the head light inner plastic cover.





### 3) Remove fender.



Remove (7) 7mm from the wheel well.  
Note: Your vehicle may have different size bolts or type of fasteners.

Remove (2) 7mm bolts from the bottom of the fender.

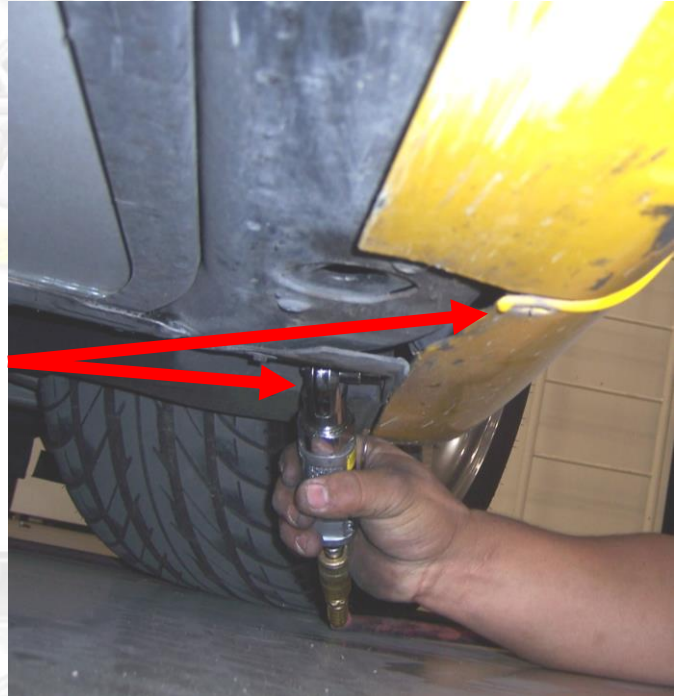

Remove (1) 7mm bolt by pulling on the fender and removing the plastic or foam cover located by the factory hinges. Pull on the fender and use a long extension to remove the 7mm bolt.

Remove (2) 10mm nuts (solid line) and (3) 7mm bolts (dash line).

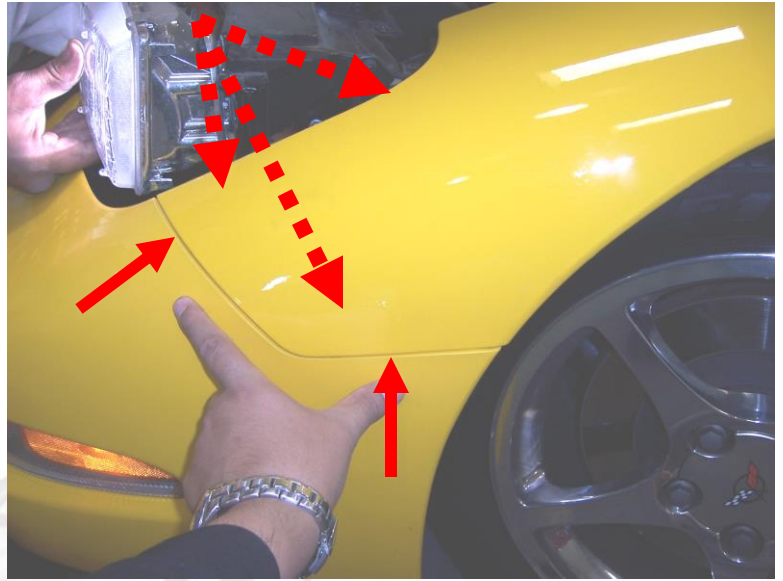

Remove (7) T-15 Torx screws securing the top of the fender, at this point you will be able to remove the fender.



#### 4) Prepare body for new Vertical Door Inc. system:

Close door and use painters tape to secure the door to the body in preparation for factory hinge removal.

***Insert the spacers after you have removed the factory hinges.***

Remove (4) 13mm bolts that secure the factory hinges.

*(You can make spacers by using paint mixing sticks and putting approx. 8 to 10 turns of tape.)*

*Note: spacers not included.*

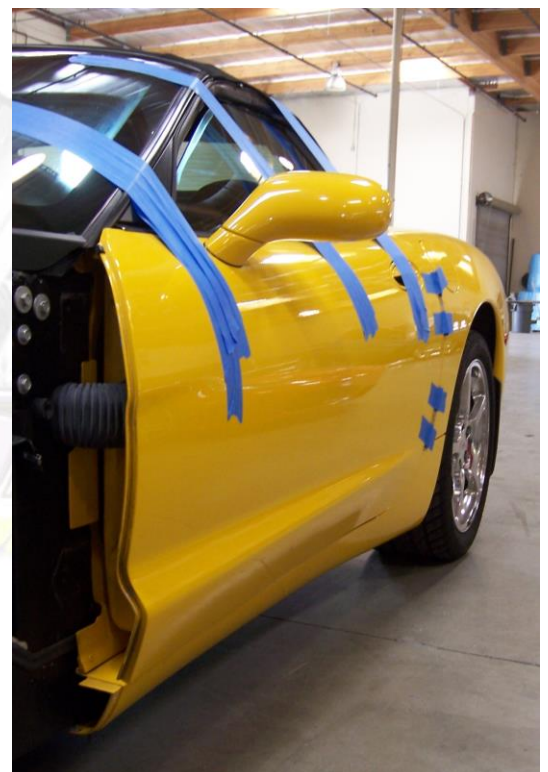



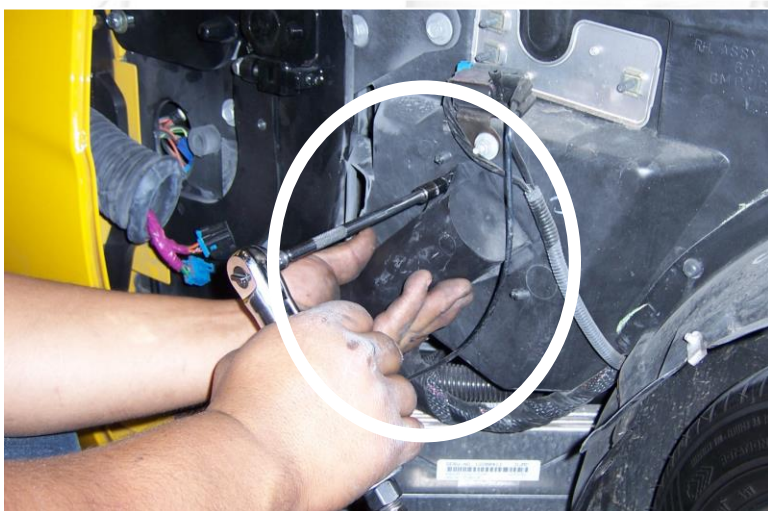

You will have to reposition the filter on the passenger's side as showed on the picture.

VERTICAL DOORS, INC.  
VerticalDoors.com

You will have to cut the apron on both sides of the car as showed, to make room for the new VDI system.



## 5) Install the New Vertical Doors Inc. System:

Use the fork to loosen the factory wire boot and unplug the wire harness, this will allow you to install the new VDI system. Make sure it's flat against all surfaces.

*Hint\* Tighten the bolts on the door first and the bolts on the body second.*

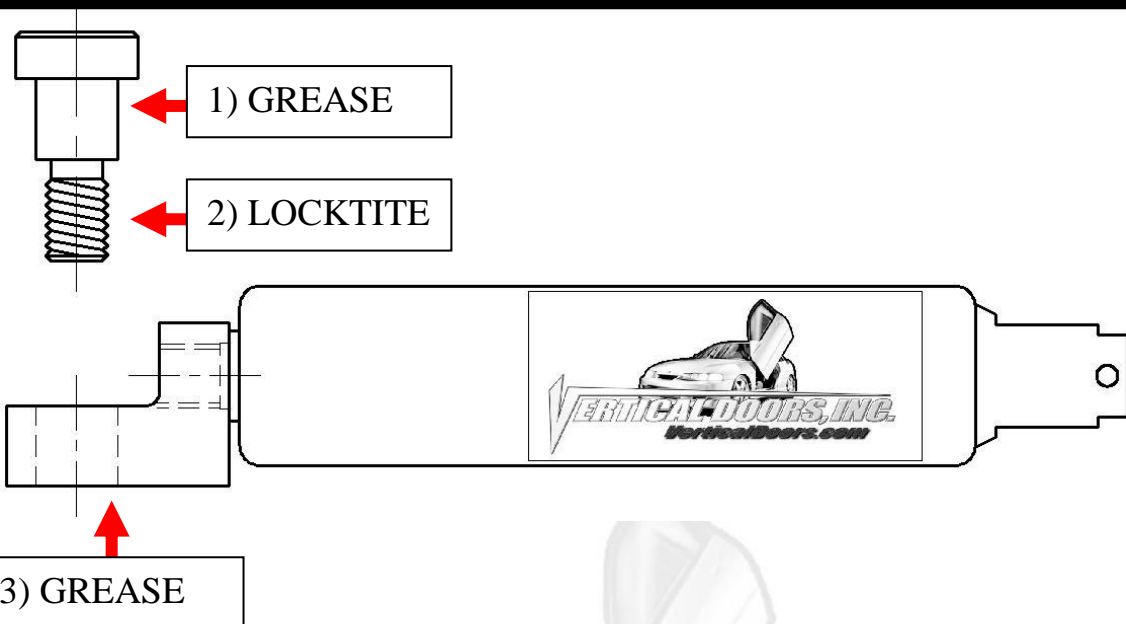
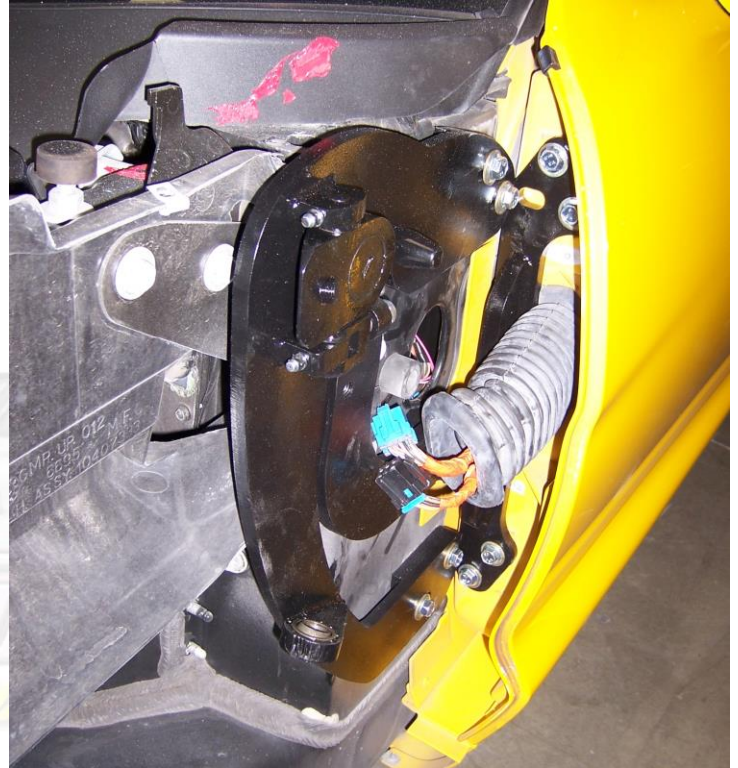

**\*IMPORTANT STEP: DO NOT SKIP THIS STEP. THIS STEP IS CRUCIAL IN YOUR INSTALLATION PROCESS, IF THIS STEP IS NOT COMPLETED WHEN INSTALLING THE VERTICAL DOOR KIT; ALL WARRANTIES ARE VOIDED, AND MAY CAUSE FUTURE PROBLEMS WITH YOUR VERTICAL DOOR SYSTEM.**

1<sup>ST</sup>, make sure you put grease on the body of shoulder bolt where the arrow is pointing.

2<sup>ND</sup>, make sure you put red Loctite, where the arrow is pointing, on thread of shoulder bolt.

3<sup>RD</sup>, make sure you put grease on the bottom side of the shock end.



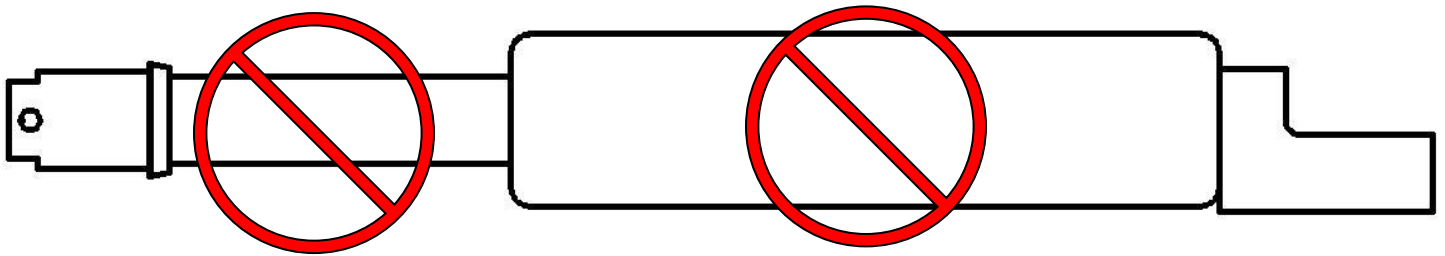

**WARNING! THE USE OF ANY TYPE PLYERS, PAINT OR FOREING MATERIALS ON THE SHOCK'S BODY OR SHAFT WILL VOID THE WARRANTY.**

6) Once hinge is locked in place, break nut #1 then turn Allen set screw #2 on fig until it hits the block then open the door and continue to adjust until the door matches with the striker, open and close door making sure it closes like factory.

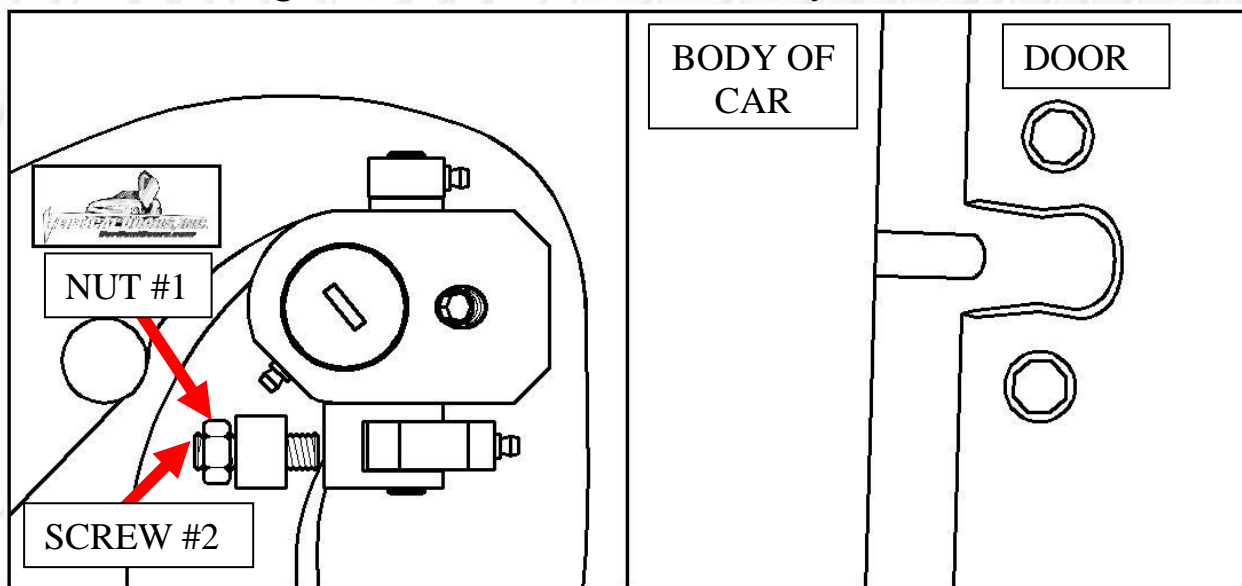

*Hint\*(leave #1 nut loose until shock is installed Allen set screw will have to be re-adjusted after shock is installed.*

7) Install the shock.

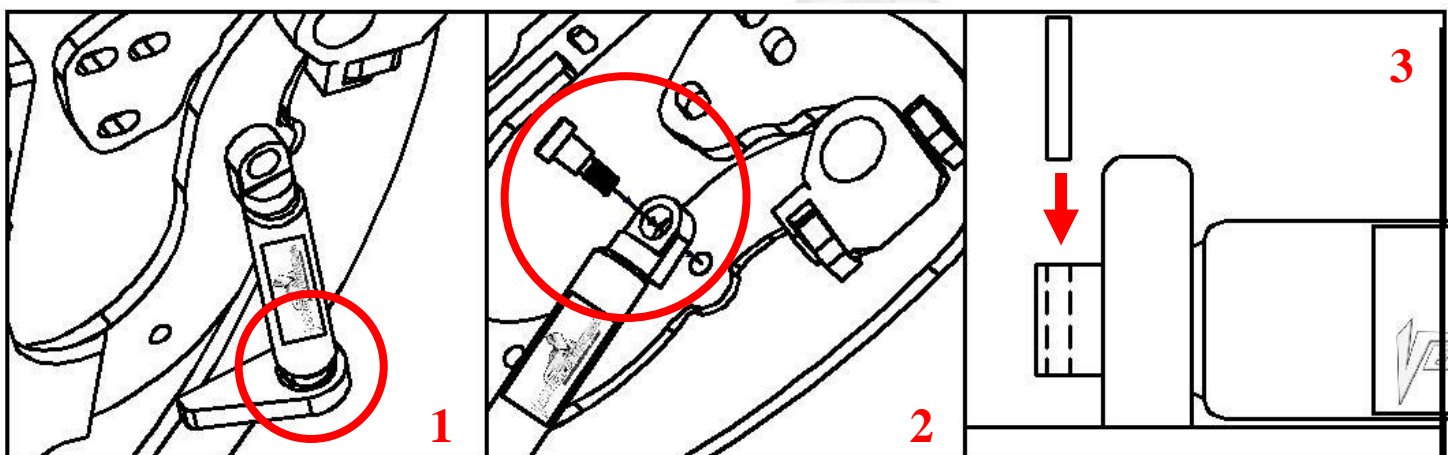

*Hint\* (You will need a helper to raise the door). (Slip the spherical rod mount into the spherical ball bearing (1). Using a 1/4 Allen wrench, tighten the screw into the swing arm (2). After the shock is installed secure it by installing the pin in the bottom shock end (3).*



**8)** After shock is installed re-install door panel and lift the door. Adjust door opening screw #3 clockwise until distance between nub and swing arm is enough so that the swing arm moves up and down freely.

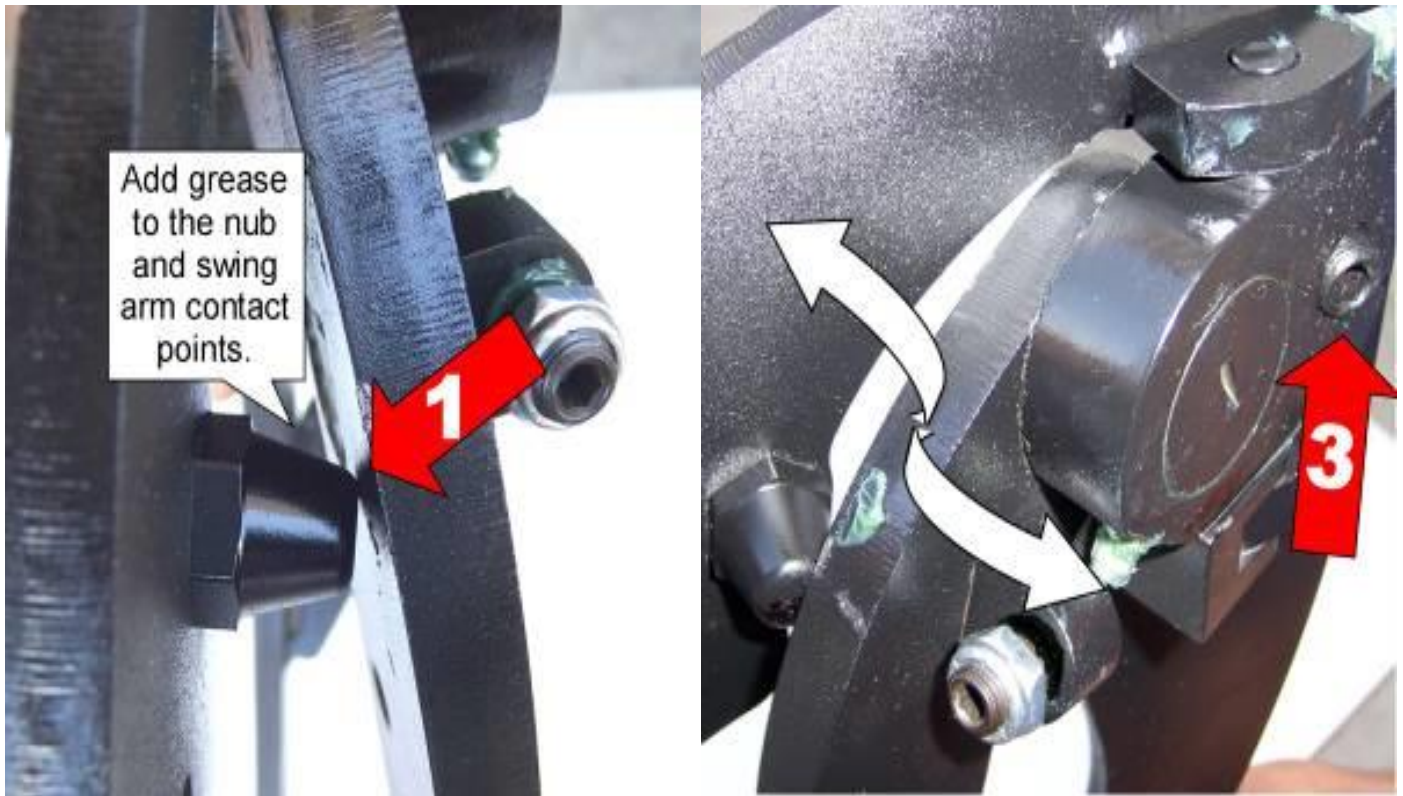

*Hint\* (Fine tune the Allen set screw (#2) to realigned striker with door. After the door is aligned, test door by opening and closing, lifting and lowering door several times.*

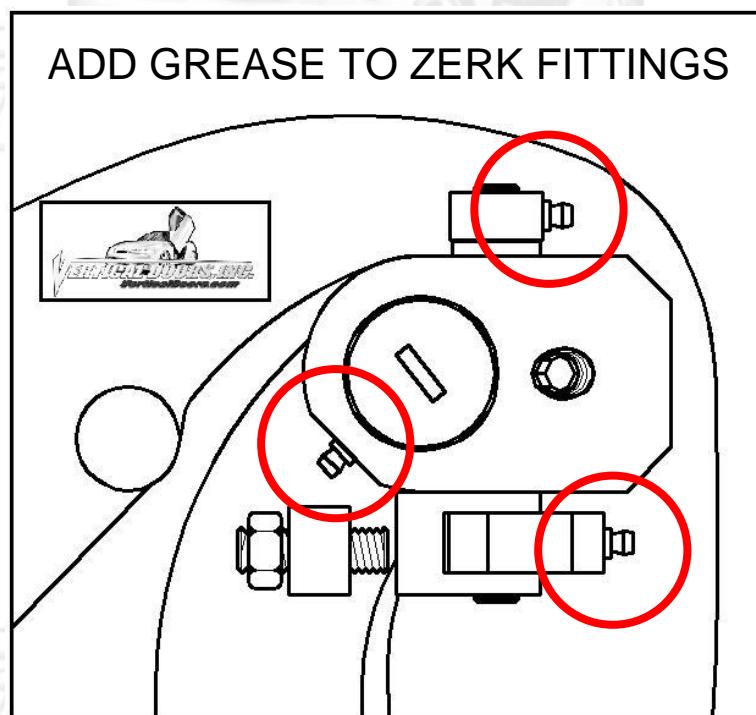

**Note:** Do not install fender until the adjustment of the door is accurate, and the set screw is tightly secure. Also make sure everything is tight, adjustment is set and everything is Locktite.

## 9) Modify the factory wire boot:

You will have to cut the factory wire boot in half; half will be used for the body and the other half will be used for the door. Use supplied wire loom to protect exposed wires.

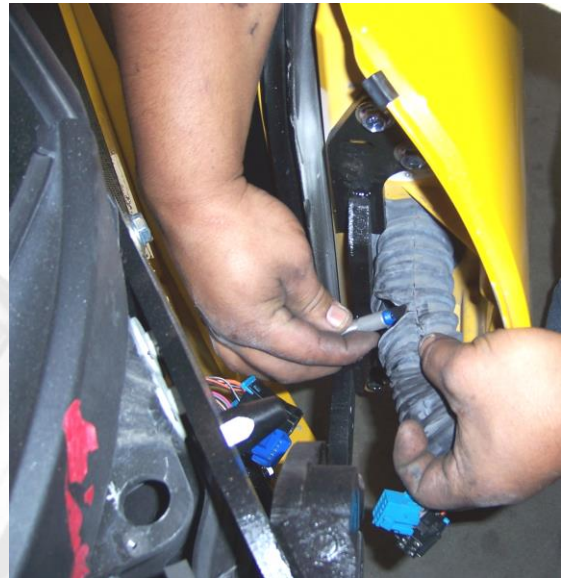

Your VDI system should look like the picture on the right.



**10)** Trim the inside of the fender and door as shown.

*Use painter's tape to protect the paint that will not be cut.*



**11)** Cut the inner lip of your fender to make room for the new Vertical Doors Inc. system.



Use a power cutter and grinder to cut and take any sharp edges off. Use black door trip to give it a finish look.

**12)** Lift the door and Replace the fender by reversing step 2 and 3.

*Hint\*(Make sure the electrical wires don't get pinched enough to damage wires)*

**13)** For the other side just follow the same steps.

Note: some models are equipped with door trims. If your vehicle has one you may need to move the fender trim forward about 1 inch.



Thank you for your purchase of the  
**CORVETTE C5**  
**1997-2004**

# ***VERTICAL DOORS INC. SYSTEM***

*Simply Uplifting*

*VERTICAL DOORS, INC.*  
*VerticalDoors.com*



*VERTICAL DOORS, INC.*  
*VerticalDoors.com*

**NOTE:**

Vertical Doors Inc. assumes no responsibility for any damages caused by improper installation